

THIS DRAWING IS UNPUBLISHED. RELEASED FOR PUBLICATION  
 © COPYRIGHT BY TYCO ELECTRONICS CORPORATION. ALL INTERNATIONAL RIGHTS RESERVED.

| LOC | DIST | REVISIONS   |                           |           |        |
|-----|------|-------------|---------------------------|-----------|--------|
| P   | LTR  | DESCRIPTION | DATE                      | DWN       | APVD   |
| GP  | 00   | H           | REVISED PER ECO-08-007460 | 17JUN2008 | ZMRCWR |

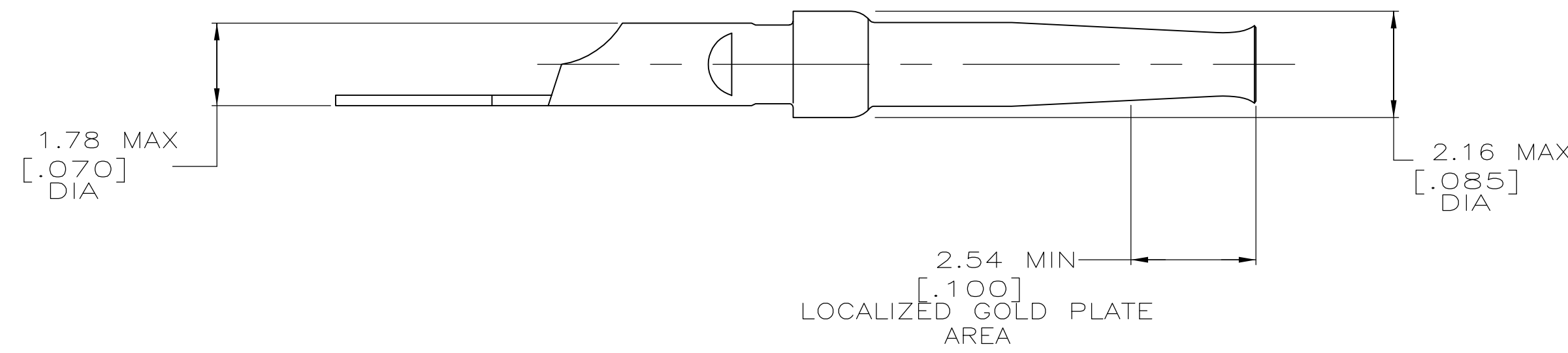
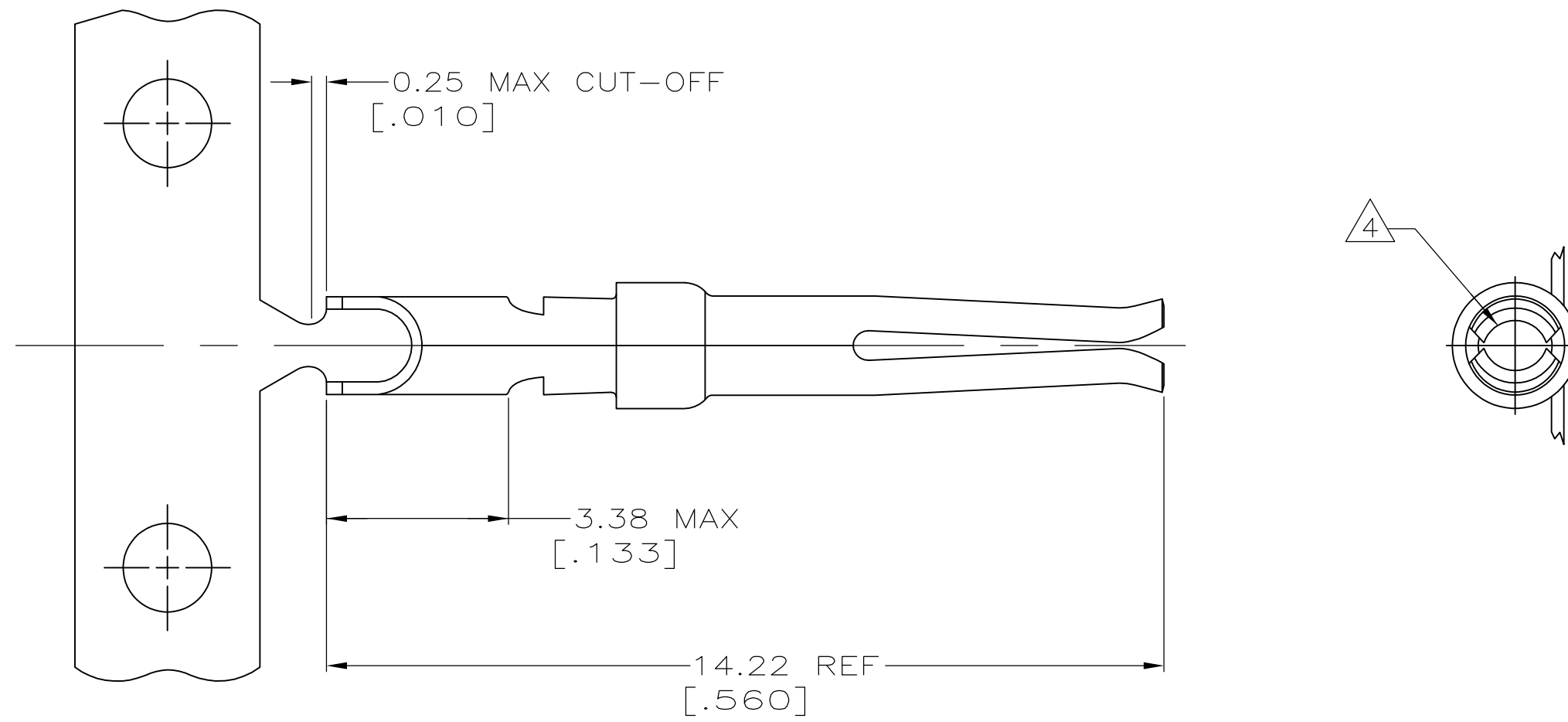

- 1 PHOSPHOR BRONZE PER QQ-B-750.
- 2 GOLD PLATED IN LOCALIZED GOLD PLATE AREA AS FOLLOWS:  
 PLATED WITH 0.76µm [.000030] GOLD IN LOCALIZED GOLD PLATE AREA, GOLD FLASH ON REMAINDER, OVER 1.27µm [.000050] MIN NICKEL.  
 OR  
 GOLD FLASH OVER PALLADIUM-NICKEL PLATE, 0.76µm [.000030] MIN TOTAL IN LOCALIZED GOLD PLATE AREA, GOLD FLASH ON REMAINDER, OVER 1.27µm [.000050] MIN NICKEL.
- 3 GOLD PLATING PER MIL-G-45204, NICKEL PLATING PER QQ-N-290.
- 4 WILL ACCEPT 1.02 [.040] DIA PIN.
- 5. 1.17 [.046] MAX DIA CONDUCTOR (UP TO 18 AWG).

| PACKAGING  | TYPE        | PART NUMBER |
|------------|-------------|-------------|
| SMALL PACK | LOOSE PIECE | 1-66569-0   |
| STANDARD   | LOOSE PIECE | 66569-3     |
| -          | STRIP       | 66569-2     |

|   |               |                                |   |                    |     |       |     |       |     |       |     |       |     |        |     |        |
|---|---------------|--------------------------------|---|--------------------|-----|-------|-----|-------|-----|-------|-----|-------|-----|--------|-----|--------|
| THIS DRAWING IS A CONTROLLED DOCUMENT.  |               | DWN<br>D.HARDY<br>08 NOV 95    | Tyco Electronics Corporation<br>Harrisburg, PA 17105-3608         |                    |     |       |     |       |     |       |     |       |     |        |     |        |
| DIMENSIONS:<br>mm [INCHES]  |               | CHK<br>R.STONE<br>14 NOV 95    |   |                    |     |       |     |       |     |       |     |       |     |        |     |        |
| TOLERANCES UNLESS OTHERWISE SPECIFIED:  |               | APVD<br>C.STINSON<br>06 DEC 95 |   |                    |     |       |     |       |     |       |     |       |     |        |     |        |
| <table border="1"> <tr><td>0 PLC</td><td>± -</td></tr> <tr><td>1 PLC</td><td>± -</td></tr> <tr><td>2 PLC</td><td>± -</td></tr> <tr><td>3 PLC</td><td>± -</td></tr> <tr><td>4 PLC</td><td>± -</td></tr> <tr><td>ANGLES</td><td>± -</td></tr> <tr><td>FINISH</td><td>± -</td></tr> </table> |               | 0 PLC                          |   |                    | ± - | 1 PLC | ± - | 2 PLC | ± - | 3 PLC | ± - | 4 PLC | ± - | ANGLES | ± - | FINISH |
| 0 PLC   | ± -           |                                |   |                    |     |       |     |       |     |       |     |       |     |        |     |        |
| 1 PLC   | ± -           |                                |   |                    |     |       |     |       |     |       |     |       |     |        |     |        |
| 2 PLC   | ± -           |                                |   |                    |     |       |     |       |     |       |     |       |     |        |     |        |
| 3 PLC   | ± -           |                                |   |                    |     |       |     |       |     |       |     |       |     |        |     |        |
| 4 PLC   | ± -           |                                |   |                    |     |       |     |       |     |       |     |       |     |        |     |        |
| ANGLES  | ± -           |                                |   |                    |     |       |     |       |     |       |     |       |     |        |     |        |
| FINISH  | ± -           |                                |   |                    |     |       |     |       |     |       |     |       |     |        |     |        |
| MATERIAL<br>1   | FINISH<br>2 3 | APPLICATION SPEC<br>-          | NAME<br>SOCKET CONTACT, SIZE 20 DF,<br>WITH SOLDER CUP, AMPLIMITE | RESTRICTED TO<br>- |     |       |     |       |     |       |     |       |     |        |     |        |
| CUSTOMER DRAWING  |               | WEIGHT<br>-                    | SIZE<br>A2  | CAGE CODE<br>00779 |     |       |     |       |     |       |     |       |     |        |     |        |
|   |               | SCALE<br>10:1                  | DRAWING NO<br>C=66569   | REV<br>H           |     |       |     |       |     |       |     |       |     |        |     |        |